

Access controlled... Future secured.

PORTFOLIO

VEHICLE PRODUCTS



VEHICLE



SHORT AND MEDIUM-LENGTH BARRIERS

BL 10

- Manual rising barrier
- Max. 8 m



BL 12

- Medium performance rising barrier
- Opening time: 1.5 - 2.2 sec.
- Max. 4 m



BL 229

- Universal high performance rising barrier
- Opening time: 1 - 4 sec.
- Max. 6 m



BL 229 Toll

- Fast rising barrier
- Opening time: 0.6 - 1.7 sec.
- Length: 3 m



EXTRA-LONG BARRIERS

BL 40

- Opening time: 3.5 sec.
- Max. 8 m



BL 41

- Opening time: 3.5 sec.
- Max. 12 m



BL 52

- Opening time: 8 - 12 sec.
- Max. 14 m

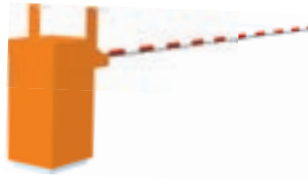

APPLICATION EXAMPLES

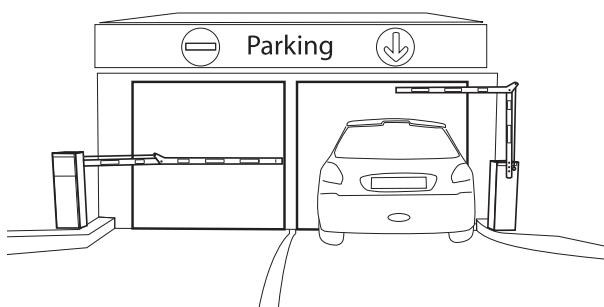

Parking

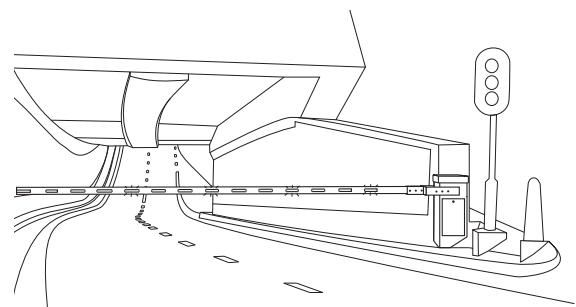

Traffic management

SECURITY BARRIERS

BL 43

- Security barrier
- Opening time: 3.5 sec.
- Max. 6 m



BL 53

- Extra-long security barrier
- Opening time: 5 – 10 sec.
- Max. 8 m



BL 44

- Fast security barrier
- Opening time: 2 sec.
- Max. 4 m

BL 46

- Rising barrier with a folding fence
- Opening time: 3.5 sec.
- Max. 7 m



RISING FENCED BARRIERS

BLG 76

- Rising fenced barrier
- Opening time: 8 - 12 sec.
- Height: 1.9 m
- Width Max. 5.5 m



BLG 77 L

- Heavy duty rising fenced barrier
- Opening time: 7 - 10 sec.
- Height: 1.8 m
- Width: 6.4 m



BLG 77 H

- Heavy duty rising fenced barrier
- Opening time: 7 - 10 sec.
- Height: 3.0 m
- Width: 5.1 m



APPLICATION EXAMPLES

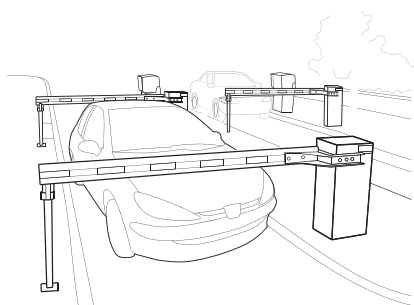

Secured parking areas

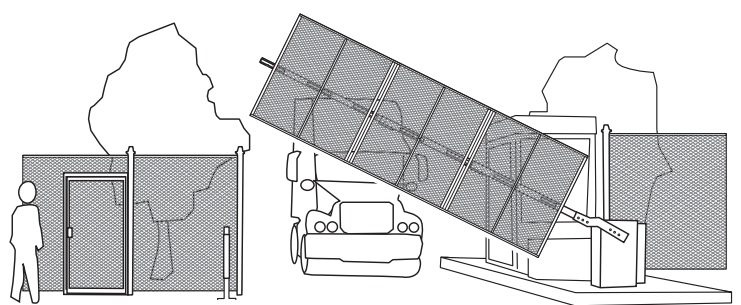

Site closure

RISING BOLLARDS

RB 60-80

- Rising bollards
- Rising speed: 6 - 8 sec.
- Height: 600 mm or 800 mm

RB 70 S

- High-security rising bollard
- Rising speed: 7 sec. (1 sec. optional)
- Height: 700 mm



ROAD BLOCKERS

RSB 70

- Surface-mount road blocker
- Rising speed: 3 sec.
- Height: 350 mm
- Width: 2 m or 3 m

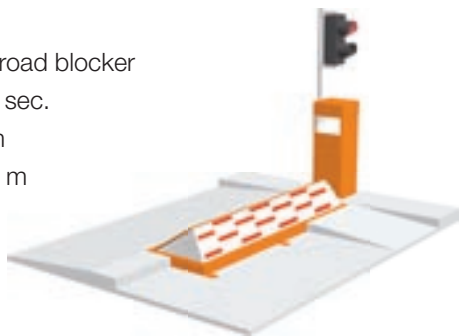

RSB 76 E

- High-security road blocker (K4)
- Rising speed: 3 sec.
- Height: 665 mm
- Width: 3 m or 3.5 m or 4 m



RSB 71

- Dissuasive road blocker
- Rising speed: 3 sec.
- Height: 350 mm
- Width: 3 m



RSB 76 H

- High-security road blocker (K4) (hydraulic)
- Rising speed: 3 sec.
- Height: 665 mm
- Width: 3 m or 3.5 m or 4 m

APPLICATION EXAMPLES

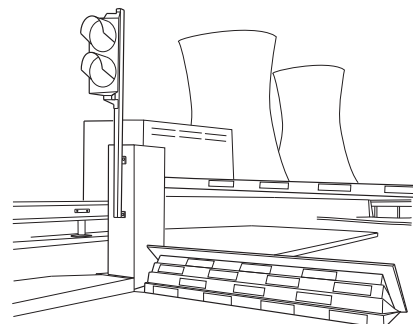

Sensitive sites

ACCESSORIES

BOR 235 simple / double height

- Housing for integration of accessories
- Car height or truck height
- Ideal with rising barriers or road blockers



PST simple / double height

- Post for integration of accessories
- Car height or truck height
- Ideal with rising barriers or road blockers



COLBE

- Column for integration of accessories
- Ideal with rising bollards



Fences and skirts

- To reinforce the security level



Tip supports

- To support barrier arms
- To reinforce the security level



Detection and command

- For safety and access control



Customisation

- To fit in perfectly within your site

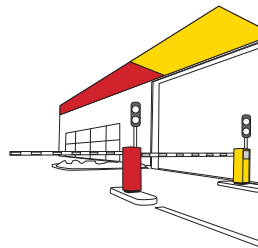

APPLICATION EXAMPLES

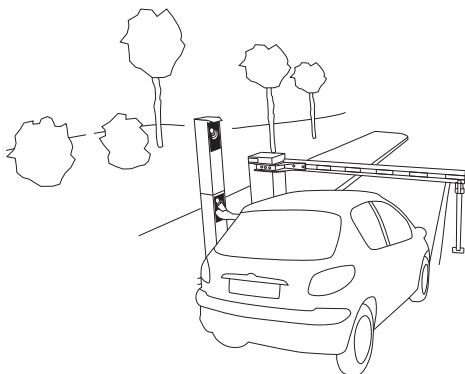

Entrance control

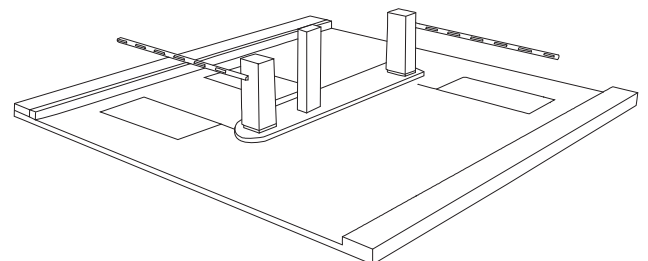

Automatic entrance and exit

Select your barrier here

| | Security Level | Maximum Passage Width | | Passages/minute ⁽¹⁾ | Opening Speed (sec.) | Arm Type | | | | | Applications | | | | | Price Range |
|---|----------------|-----------------------|-----|--------------------------------|----------------------|----------|------------|-------------|-----------|--------------------------|--------------|-------------------|---------|------------------|-----------------|-------------|
| | | (m) | | | | Standard | Reinforced | Articulated | Swing-off | Protecta™ ⁽²⁾ | Fenced | Highway and Tolls | Parking | Perimeter Access | Sensitive Sites | |
| Short and Medium-Length Barriers | | | | | | | | | | | | | | | | |
| BL 10 Manual | 1 | 8 | | 1 | N/A | ● | | | | | | | | ● | | € |
| BL 12 | 1 | 4 | | 15 | 1.5 - 2.2 | ● | | | | | | ● | | ● | | € |
| BL 229 | 2 | 6 | | 25 | 1 - 4 | ● | | ●* | ●* | | | ● | | ● | | €€ |
| BL Toll | 1 | 3 | | 50 | 0.6 - 1.7 | ● | | | ● | ●* | | ● | | | | €€ |
| Extra-long Barriers | | | | | | | | | | | | | | | | |
| BL 40 | 3 | 8 | | 8 | 3.5 | ● | | | | | ●* | | | ● | ● | €€€ |
| BL 41 | 3 | 12 | | 8 | 3.5 | ● | | | | | | | | ● | ● | €€€ |
| BL 52 | 3 | 14 | | 3 | 8 - 12 | ● | | | | | ●* | | | ● | ● | €€€€ |
| Security Barriers | | | | | | | | | | | | | | | | |
| BL 43 | 4 | 6 | | 8 | 3.5 | | ● | | | | | | ● | ● | ● | €€€ |
| BL 44 | 4 | 4 | | 15 | 2 | | ● | | | | | | ● | ● | ● | €€€ |
| BL 46 | 4 | 7 | | 8 | 3.5 | ● | | | | | ● | | | ● | ● | €€€ |
| BL 53 | 4 | 8 | | 4 | 5 - 10 | | ● | | | | | | | ● | ● | €€€€ |
| | | w (m) h (m) | | | (sec.) | | | | | | | | | | | |
| Rising Fenced Barriers | | | | | | | | | | | | | | | | |
| BLG 76 | 4 | 5.5 | 1.9 | 3 | 8 - 12 | ● | | | | | ● | | | ● | ● | €€€€ |
| BLG 77 - H | 5 | 5.1 | 3.0 | 4 | 7 - 10 | | ● | | | | ● | | | ● | ● | €€€€ |
| BLG 77 - L | 5 | 6.4 | 1.8 | 4 | 7 - 10 | | ● | | | | ● | | | ● | ● | €€€€ |

Select your blocker here

| | Security Level | Dimensions of the Obstacle | | Passages/minute ⁽¹⁾ | Opening Speed (sec.) | Installation : Recessed (pit) | Installation : Surface-mount | Operator | | | | Applications | | | | Impact Resistance | Price Range |
|------------------------|----------------|----------------------------|-------------|--------------------------------|----------------------|-------------------------------|------------------------------|-------------------|-----------|-----------|--------|-------------------|---------|------------------|-----------------|--------------------|-------------|
| | | Diameter (mm) | Height (mm) | | | | | Electromechanical | Hydraulic | Pneumatic | Manual | Highway and tolls | Parking | Perimeter access | Sensitive Sites | | |
| Rising Bollards | | | | | | | | | | | | | | | | | |
| MB 50 | 3 | 275 | 500 | 1 | 2.5 | ● | | | | ● | ● | | | | ● | 1500 kg at 45 km/h | €€ |
| RB 60 / RB 80 | 3 | 275 | 600/800 | 3 | 6 / 8 | ● | | | ● | | | | | | ● | 1500 kg at 45 km/h | €€€ |
| RB 70S | 5 | 275 | 700 | 3 | 7 | ● | | | ● | | | | | | ● | 6800 kg at 48 km/h | €€€€ |
| | | Width (m) | Height (mm) | | (sec.) | | | | | | | | | | | | |
| Road Blockers | | | | | | | | | | | | | | | | | |
| RSB 70 | 3 | 2 / 3 | 350 | 8 | 3 | ● | ● | | | | | ● | ● | | | 1500 kg at 26 km/h | €€ |
| RSB 71 | 4 | 3 | 350 | 8 | 3 | ● | ● | | | | | ● | ● | ● | | 1500 kg at 26 km/h | €€€ |
| RSB 76H | 5 | 3 / 3.5 | 665 | 8 | 3 | ● | ● | | | | | ● | ● | | | 6800 kg at 48 km/h | €€€€ |
| RSB 76E | 5 | / 4 | | 8 | 3 | ● | ● | | | | | | ● | ● | | (K4 theoretical) | €€€€ |

Legend: * Optional

Security Level: 1 = Deterrent 5 = High Security | Price Range: € = Low End €€€€ = High End

⁽¹⁾ Including access control for each vehicle ⁽²⁾ Carbon Arm